

PGF32I-1

30cm Linear Domino Induction Cooktop



EAN 8017709138042

Dimensions	310mmW x 70mmH x 512mmD
Finish	Stainless steel
Installation	Topmount
No. of burners	2
Capacity	front: Ø140/100mm, 1400W 2500W boost rear: Ø180/100mm, 1850W 2500W boost
Temperature Control	9 Power levels + boost
Power	220-240V, 50/60Hz 3600W 1.5A Connection
Safety	Residual heat indicators
Supplied Accessories	No
Optional Accessories	Domino stainless steel joining kit - (LGPGF)
Warranty	Two years parts and labour

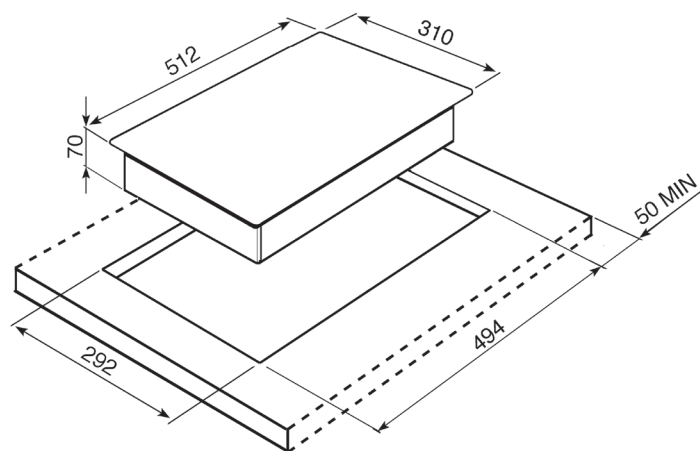

PLEASE NOTE: Drawings are not to scale. They are to assist only.

WARNING: Technical specifications and product sizes can be varied by the manufacturer, without notice. Cutouts for appliances should only be by physical product measurements. The above information is indicative only.

