

SL83 BBQ 1200M

120CM BBQ MARINE GRADE HOOD



let's get
Sirius
with rangehood design



SL83 BBQ 1200M

Features and Benefits:

ALFRESCO DESIGN	Specially designed for outdoor under-cover use, custom built high power motors, minimises smoke and odours from entering adjoining living areas
LED LIGHTS—SWIVEL ADJUSTABLE	Energy efficient, Better illumination of cooking area, Longer life span than standard globes, Modern aesthetic
25MM COMMERCIAL STAINLESS STEEL BAFFLE FILTERS	Commercial design, Dishwasher safe, Designed for greatest air movement for maximum performance, Easy to fit and remove, Lifetime filters: last the life of the hood
LARGER DUCTING DIAMETER	200mm -Greater extraction and lower dB rating due to less air flow restriction , Can be rear vented into 2x 150mm
CLEAN FILTER INDICATOR	Takes the guessing game out of maintaining your hood
MADE IN ITALY	Units are designed specifically for the Australian market and manufactured in Italy by dedicated boutique specialist manufacturer
WARRANTY	3 years (6 years when Sirius ducting is used)

Distributed by Arisit Pty Ltd

40-44 Mark Anthony Drive, Dandenong South VIC 3175 Ph: 1300 762 219 Fax: 03 9768 0838 Website: www.arisit.com

SL83 BBQ 1200M

120CM BBQ MARINE GRADE HOOD



let's get
Sirius
with rangehood design

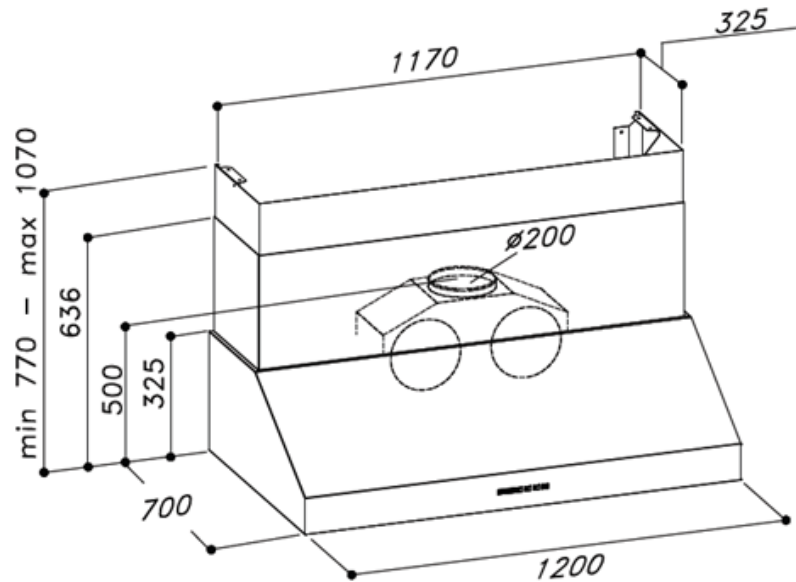

Technical Specifications:

MODEL	SL83 BBQ 1200M
CONTROL PANEL	ELECTRONIC CONTROL
MOTOR	TWIN ALUMINIUM EBM
EXTRACTION	2400 m/3h
DUCTING DIAMETER	200mm
LIGHTS	5 x ADJUSTABLE LED
FILTER	25mm COMMERCIAL STAINLESS STEEL BAFFLE
ELECTRICAL REQUIREMENT	10A
PRODUCT DIMENSIONS	1200 x 700 x 770-1070

Open grill BBQs have the higher height restriction to prevent flames caused by fat fires being sucked up into the hood. You must leave at least 900 mm (full hotplate) or 1200 mm (open grill) clearance.

WARNING: technical specifications and product sizes can be varied by the manufacturer, without notice. Cut outs for appliances should only be by physical product measurements. The above information is indicative only.

Distributed by Arisit Pty Ltd

40-44 Mark Anthony Drive, Dandenong South VIC 3175 Ph: 1300 762 219 Fax: 03 9768 0838 Website: www.arisit.com